

# Euro Twin Bar

## Lite

Cat. No. ETBL



Two individual spot lights which can be aimed in two entirely different directions. Each lite has fully adjustable arms allowing 360 degree rotation and 0 - 90 degree elevation adjustment with built in glare guards.

The heads are mounted on a 250mm (10") bar with twin ground spikes.

### Ordering Information

#### Luminaire Type

ETBL - Euro Twin Bar Lite

#### Material

COP - Copper  
SS - 316 Stainless Steel

#### Accessories

CJK150 - Cable Joint Kit  
EFL - Frosted Lens  
/300 - 300mm (12") Spike

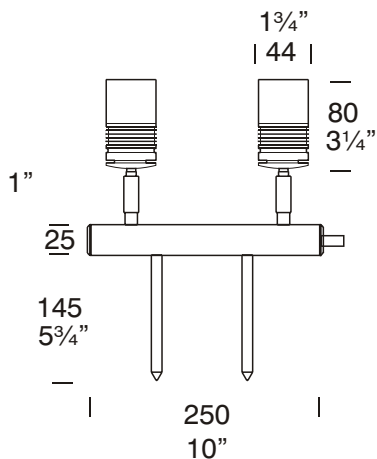

Ordering Example ETBL COP - Euro Twin Bar Lite in Copper

ETBL /300 SS - Euro Twin Bar Lite in 316 Stainless Steel 300mm (12") Spike

EFL - Frosted Lens

*(Accessories ordered separately)*



**FACTORY:** Ph. 64-9-570 2484 Fax. 64-9-570 1254. 31 Thomas Peacock Place, Auckland, New Zealand

**USA:** Ph. 310 560 7310 Fax. 1 877 692 4589.

3237 Long Island St, W. Sacramento, California 95691

hunza@hunza.co.nz www.hunza.co.nz

Manufactured in New Zealand

Specifications may change without notice.

© 2002 Hunza Holdings Ltd

### Luminaire Construction

CNC machined from one of the following metals:

CNC machined from one of the following metals:

Copper:

Body 45.4mm (1 3/4") rod.

Bar:

25.4mm x 1.42mm (1" x 1/16") tube.

End Cap:

25.4mm x 10 (1" x 3/8") brass rod.

Spike:

11mm x 150mm (3/8" x 6") copper.

316 Stainless Steel :

Body:

45.4mm (13/4") rod.

Bar:

25.4mm x 10 (1" x 3/8") rod.

25.4 x 1.42mm (1" x 1/16") tube.

Spike:

11mm x 150mm (3/8" x 6") rod.

### Mounting

Spike 150mm (6") 300mm (12") mounted directly into the ground.

### Features

#### Lens:

3mm (1/8") clear tempered shatter resistant glass.

Life Time Warranty.

#### Gaskets:

Silicone, iron impregnated 220°C (428°F).

#### Lamp Holders:

GU4 - 350°C (662°F) ceramic multi contact lamp holder with 250°C (480°F) teflon cables.

#### Accessories:

Cable Joint Kit (Cat. CJK150).  
Not approved for USA /Canada.

Frosted Lens (Cat. EFL).

Ground Spike 300mm (12")  
(Cat. /300).

#### Swivels:

Copper luminaires - 360° rotation and 0 - 90° elevation, solid brass with anti rust spring.

Stainless Steel luminaires - 360° rotation and 0 - 90° elevation, full stainless steel construction.

### Standards

#### IP66

USA and Canada:

Not Approved

#### Luminaire Weight

Cop 2.840kg (6lb 4oz)  
SS 2.414kg (5lb 5oz)

#### Power Supply

HUNZA® Inground or Wall Mount  
Transformer: not included.

#### Lamp Type

MR11 GU4 - 2 x 20 watt lamps max.

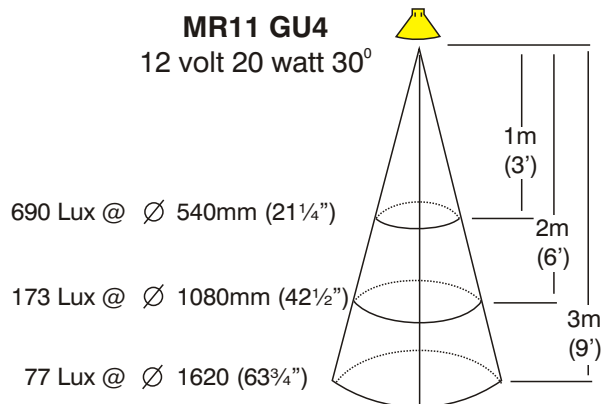
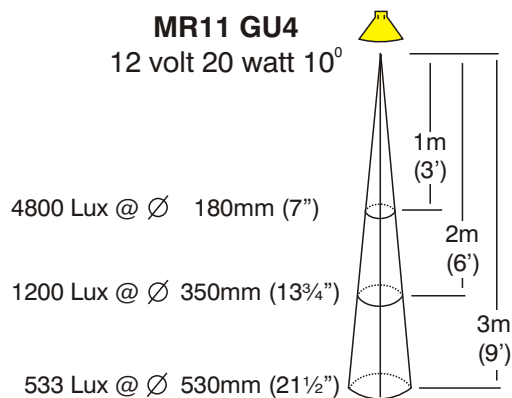

**FACTORY:** Ph. 64-9-570 2484 Fax. 64-9-570 1254. 31 Thomas Peacock Place, Auckland, New Zealand  
**USA:** Ph. 310 560 7310 Fax. 1 877 692 4589. 3237 Long Island St, W. Sacramento, California 95691  
 hunza@hunza.co.nz www.hunza.co.nz  
 Specifications may change without notice. Manufactured in New Zealand  
 © 2002 Hunza Holdings Ltd